

Markem-Imaje's commitment: to transfer more value to you.

By making total cost of ownership and the environment essential to the design of the SmartDate X40, Markem-Imaje is firmly committed to constantly enhancing the standards of thermal transfer technology. The SmartDate X40 represents a transparent, advanced coding solution including long term cost control, planet conscious design, greater uptime and increased performance on the line even in harsh environmental conditions.

Cost reduction

- Large range of ribbon widths, 20 mm to 55 mm, optimizes ribbon usage.
- Includes CoLOS® Create 5.0 software with automatic ribbon optimization feature.
- Patented ribbon saving features help to minimize ribbon waste.
- Lower cost 32 mm printhead option (standard 53 mm) for applications requiring less than 35 mm ribbon.
- Standard 1100 m ribbon reduces changeovers and improves cost per print.

Operation optimization

- Real-time access to availability ratio, ribbon status and "dead-dot" detection.
- 1100 m standard ribbon length for more uptime.
- Intelligent data entry function allowing for easy and secure job management thus reducing errors.
- Intuitive CoLOS® Create 5.0 software for simple message design.

Unmatched reliability

- Unrivaled printhead warranty*.
- Zero preventative maintenance visits thanks to robust features including; direct ribbon drive and improved cassette design which contain no wear parts.
- Excellent availability ratio of up to 99.6%** without assistance due to standard 1100 m ribbon.
- IP protection option for harsh environmental conditions and frequent pressurized water cleaning

High performance printing

- Introducing intelligent printhead, with automatic setup and dead-dot detection for optimum print quality.
- Optional promotional coding feature allowing for a unique code on each pack.
- Print speeds up to 600 mm/s.
- High quality 300 dpi resolution.

Eco-initiatives

- Air consumption down to 0.4 ml/print at 2.5 bar.
- Up to 50% reduction in power consumption.
- Up to 20% less ribbon waste with new standard ribbon design.
- Power saving features within the controller improve energy efficiency.

*See conditions defined by Markem-Imaje.

**Availability ratio = Uptime / (Uptime + Downtime)

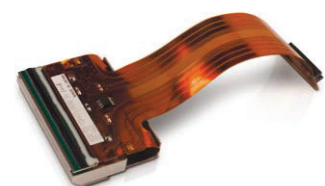
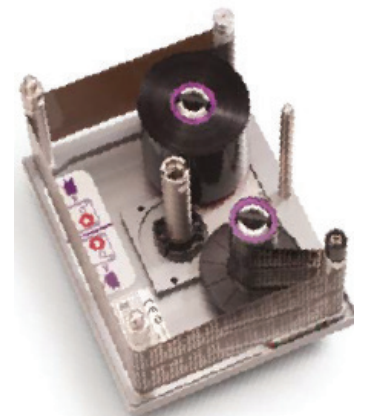

SmartDate X40 - Specifications

Print features

- Print speed:
 - Intermittent: up to 600 mm/s
 - Continuous: 10 to 600 mm/s
- Print area:
 - Intermittent: 53 mm or 32 mm x 75 mm
 - Continuous: 53 mm or 32 mm x 100 mm
- Print features:
 - Automatic printhead setup
 - Dead-dot detection
 - Intermittent and continuous printer
 - Easily changes from left to right hand with no additional parts
 - Average gap between prints 0.5 mm
 - Automatic shift codes and serial numbers
 - Multiple variable user input fields with alpha-numeric texts
- Ribbon saving mode:
 - Radial ribbon saving
 - Interlaced mode
 - Multi-print triggers
 - Negative ribbon advance
- Print specifications: Full true type font support, including non-Roman characters and symbols. Printing of real-time clock, dates and auto updating best before dates, barcodes; ITF, Code 39, Code 128, EAN 128, EAN 8, EAN 13, UPC A, UPC E, RSS linear, PDF 417, ID Matrix, QR and Composite RSS barcodes support

Other characteristics

- Supplies: Thermal transfer ribbon available in a variety of grades and colors
- Maximum ribbon length: up to 1100 m
- Minimum ribbon width: 20 mm
- Maximum ribbon width: 55 mm
- Weight:
 - Printer: 7.8 kg
 - Color controller: 4.5 kg
 - Mono controller: 4.0 kg
- Electrical power supply: 90 – 264 V with automatic switching; frequency 47/63 Hz; power 150 VA
- Air supply: 6 bar/90 psi (maximum) dry, uncontaminated
- Air consumption: down to 0.4 ml/print at 2.5 bar
- Operating temperature range: 0 to 40°C
- Humidity: 10% to 90% non-condensing

Printer

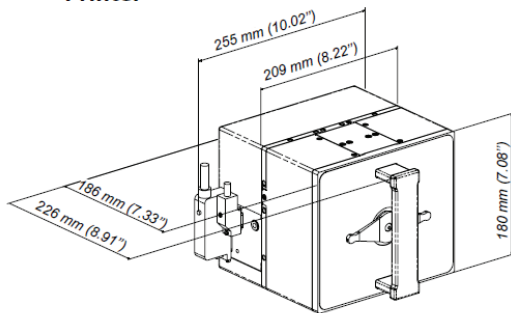

Operations

- User interface: Monochromatic user interface or color LCD touch screen for message selection, variable data entry, diagnostics and system setup
- Master/slave function to allow master control up to 4 slaves
- WYSIWYG print preview of printed message, real-time display of remaining print capacity expressed in hours and number of prints
- Full diagnostics
- Robust LED status indicators on the printer
- Webbing diagram for fast ribbon changes
- Hardware interface:
 - Inputs: "Print go" and 1 configurable input
 - Outputs: Fault, warning, and 2 configurable outputs
- S/W interface:
 - USB for downloading images, settings and data files
 - RS232, Ethernet communications standard
 - Communications protocols for PCs, PLC and packaging machines, including full remote control web server

PC software

- Included, free of charge, CoLOS® Create 5.0 for design of simple messages; compatible with CoLOS® Create Pro and Enterprise version 4 or higher.

Options

- Web UI for OEM integration
- IP protection option suitable for pressured water cleaning
- OEM control box for easy integration

Accessories

- Mounting bracket
- Encoders
- IP protection kit for installed SmartDate X40

Controller

